

HANTS® FIRE PROTECTION

UL Swing-Check-Valve

HCV-350GG



HCV-350GG

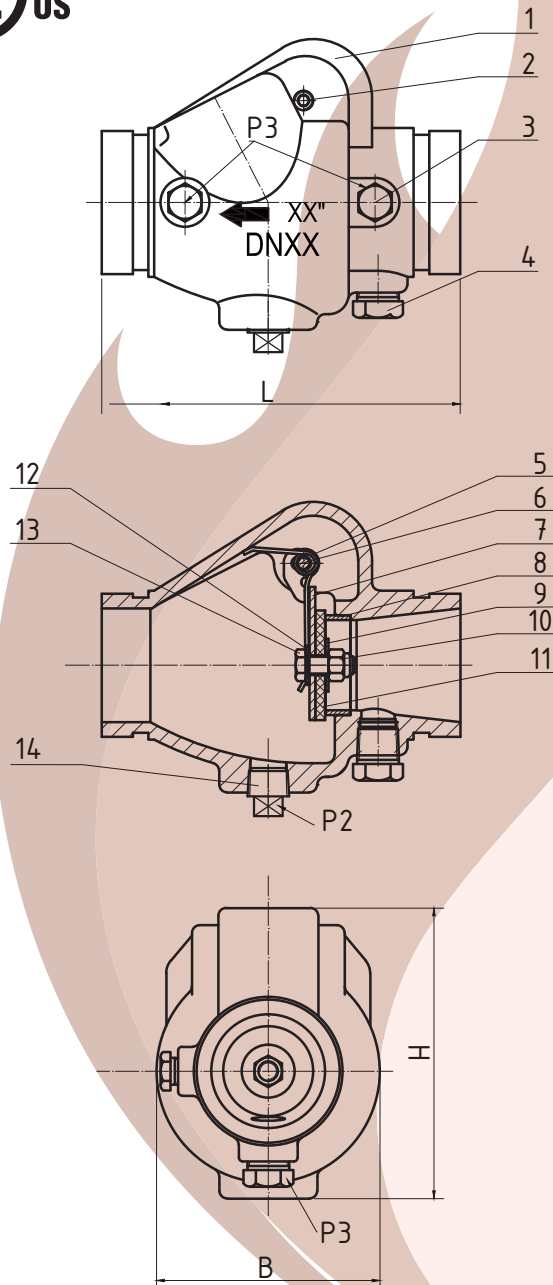

Valve Standard:
Conforms to AWWA C515

Working pressure:
350PSI

Groove Ends:
ASME B16.1 / AWWA C606

Size: 2"(DN50) to 8"(DN200)

No.	Parts Name	Material
1	Body	Ductile Iron
2	Bolt	Steel
3	Plug	Steel
4	Plug	Steel
5	Spring	SS304
6	Hinge pin	SS304
7	Clapper	SS304
8	Seat	Bronze
9	Clamping Ring	SS304
10	Locknut	SS304
11	Facing Seal	EPDM
12	Gasket	EPDM
13	Bolt	SS304
14	Plug	Steel

Size(mm)	2"	2.5"	3"	4"	5"	6"	8"
DN	50	65	80	100	125	150	200
B	100	104	128	151	189	220	279
H	131	141	166	195	223	252	303
L	169	181	198	214	248	270	325
P1	1/2-14 (NPT)						
P2	1/2-14 ,3/4-14 ,1-11.5 ,1 1/4-11.5 ,1 1/2-11.5 ,2-11.5 (NPT)						
P3	1/4-18 ,3/8-18 ,1/2-14 (NPT)						